

Operating manual: LTG-AAC-1AA-TF Laser distance sensor



SEV 23 ATEX 0648 X



Ex db [op is Ga] IIC T4 Gb
Ex tb [op is Da] IIIC T135°C Db

- Precise distance measurement with a reproducibility of < 10µm
- High measuring rate up to 2 kHz
- Measurement range 100 mm, 43mm < x < 143mm
- Stable measured values regardless of the color and brightness of the measurement object
- Analogue output signal 4 - 20mA and data interface RS422
- Easy alignment thanks to visible laser light
- Die-cast aluminum housing

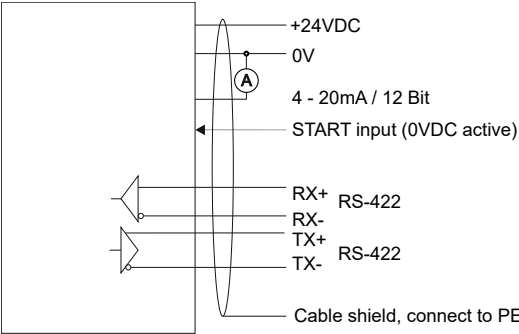
Technical Data	Type	LTG-AAC-1AA-TF
Gas Ex protection designation		II 2(1)G Ex db [op is Ga] IIC T4 Gb
Dust Ex protection designation		II 2(1)D Ex tb [op is Da] IIIC T135°C Db
For use in Ex Zones		Zones (0), 1, (20), 21
Measurement methods		Optical triangulation
Light Source		Class 2 laser according to EN 60825-1: 2008-05, P≤1mW; λ = 670nm
Measuring range		100 mm, 43mm < x < 143mm
Range start		Starting from armored glass window 43mm
Measurement center		Starting from armored glass window 93mm
Measuring range		Starting from armored glass window 143mm
Linearity		≤ 0,1 % d.M.
Reproducibility		10 µm
Temperature stability		± 0,03 % d.M./°C
Measuring rate		1kHz
Permissible ambient light		20000 lx
Spot size		750 x 1100 µm
Interface		RS422 / 16 Bit
START input, function		„low“ active, 0V starts measurement
Supply voltage, Ue		+24VDC +/-10%
Power consumption		< 2W
Analog current outputs, operating range		4 - 20mA / 12 Bit (4mA = 43mm, 20mA = 143mm) R _{load} = 250Ω results in U _{out} 1 - 5V at U _b > 11V R _{load} = 500Ω results in U _{out} 2 - 10V at U _b > 17V
Analog output, fault messages		3 mA: Outside the measuring range
Housing		Die-cast aluminum housing
Enclosure rating		IP65
Ambient working temperature range, T _{amb}		0°C up to +50°C
Storage temperature range		-20°C up to +70°C
Connection cable		Length 3 m, shielded
ATEX related markings	<p>CE 1258 Typ: LTG-AAC-1AA-TF Gas: Ⓜ II 2(1)G Ex db [op is Ga] IIC T4 Gb ATEX: IECEX: Tamb: Manufacturing date:</p>	<p>Manufacturer with Address Electrical data according to table Dust: Ⓜ II 2(1)D Ex tb [op is Da] IIIC T135°C Db SEV 23 ATEX 0648 X IECEX SEV 23.0001X 0°C up to +50°C Number 5 to 8 of the Serial Number (Year / CW)</p>
Wiring and Connection		
	<p>red +24VDC +/-10% blue 0V (GND) white 4 - 20mA / 12 Bit black START input green RX+ yellow RX- grey TX+ pink TX-</p>	

LTG-AAC-1AA-TF_e2/2024-05-06/MP

Dimensions in mm

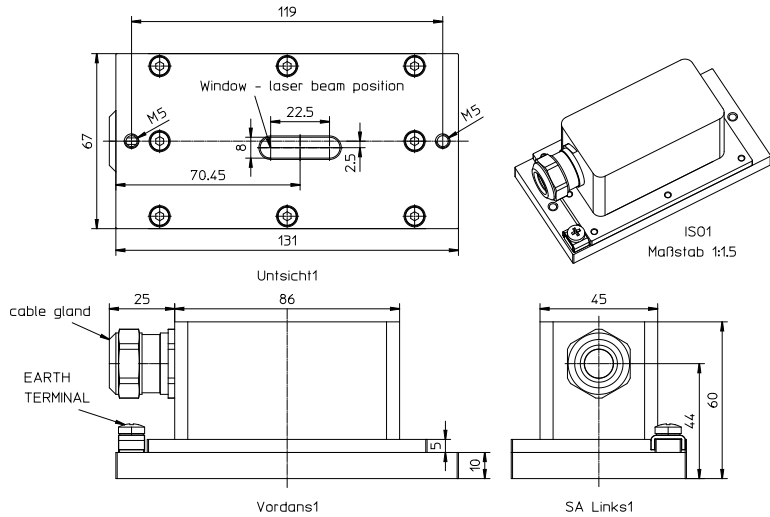

Operating Manual / EC/EU-declaration of conformity

Intended Use

The distance sensor is used for the contactless measurement of distances. It must be planned, installed and operated accordingly.

General assembly instructions

The electrical connections must be exactly as shown in the connection diagram. The sensor cables must not be laid parallel to high-current and/or high-voltage cables. The maximum limit values must not be exceeded.

Installation prescriptions for Ex hazardous locations

It is necessary to take into consideration all the valid international and national rules and regulations (DIN EN 60079-14:2014-10). Do not exceed the maximum ratings. The electrical connections must be exactly as shown in the wiring diagram. The local equipotential bonding connection is corrosion-resistant and durable to connect. The protective earth (PE) has to be connected solid with the housing. The cable shield should be connected to the protection earth (PE). Do not connect the cable shield to PE if it is not identical to the PE connected to the housing. The cable has to be installed and protected against damages. Install cables with termination fittings or puted in cable tray systems in a manner to avoid tensile stress at the termination fittings. Adequate strain relief must be provided. The end of the cable must either be installed within a certificated Ex housing or must be installed outside of any Ex area. **The housing must be installed in such a way that the risk of propagation of brush discharges when used in an explosive dust atmosphere can be avoided.** Type LTG-AAC-1AA-TF: Allowed to be installed and operated within Ex zones 1 and 21. The limited optical radiation of the laser can operate into hazardous locations zone 0 and 20.

Safety Fuse

To ensure the safety of the sensor in the event of a fault, the sensor must be connected to an external fuse of 24V and 150mA. The user is responsible for the correct installation and use of the sensor. In case of incorrect handling of the sensor, Matrix Elektronik AG rejects any liability.

Function

The device uses the principle of optical triangulation, that is, a visible, modulated point of light is projected onto the target surface. The diffuse part of the reflection of this point of light is displayed depending on distance on a position-resolving element (CMOS) by a receiver optic which is arranged to the optical axis of the laser beam in a defined angle. A signal processor in the sensor calculates the distance of the point of light on the measuring object to the sensor by means of the output signal of the CMOS elements. The distance value is linearized and output by means of the analog or RS422 interface.

Analog output

- Output current 4... 20mA: Measure object
- Output current 3mA: No object in the measuring range

Serial data output

The serial data output RS422 provides the distance of the measurement object from the sensor in digital form.

START input

The measuring process is started by applying 0VDC to the START input. If there is + 24V or "open" at the start input, the measurement is ended. We recommend planning this "START input" in the application. Use this input to select or deselect the laser. As a result, stray laser beams can be avoided when measurement is not required and the lifespan of the laser can be extended accordingly.

Maintenance

The sensor is maintenance-free. If it becomes dirty, the light passage must be cleaned carefully. No aggressive cleaning agents may be used. Repairs may only be carried out by the manufacturer.

Safety instructions for class 2 laser equipment

The standard „Safety of laser devices“ EN 60825-1 must be followed during assembly, commissioning and use. Do not look into the laser beam!

General safety instructions

The sensor is to be used in such a way that in the event of malfunction or total failure of the sensor, no people endangered or machinery damaged. The relevant EU and national regulations and guidelines must be observed during assembly, operation and maintenance. The sensors comply with the following standards: EN 61000-6-2, EN 61000-6-3, EN 61326-1.

General disposal

We reserve the right to make technical changes. The sensors are built to be as environmentally friendly as possible. Irreparable or no longer used devices must be disposed of in accordance with the applicable regulations.

EU-Declaration of Conformity

The product meets the requirements of the following standards and directives: EN IEC 60079-0:2018, EN 60079-1:2014, EN 60079-28:2015, EN 60079-31:2014, EN 60825-1:2006, EN 60825-2:2004, EN 60529, EN 61000-4-2 to EN 61000-4-6, EN 61000-6-1/-2, EN 61000-6-4, ATEX directive 2014/34/EU, Machine directive 2006/42/EC, EMC directive 2014/30/EU, RoHS directive 2011/65/EU

ATEX/IECEx-Designation:

- Gas: II 2(1)G Ex db [op is Ga] IIC T4 Gb
- Dust: II 2(1)D Ex tb [op is Da] IIIC T135°C Db
- ATEX EU-type examination certificate No.: SEV 23 ATEX 0648 X
- IECEx CoC No.: IECEx SEV 23.0001X
- Ex CB IECEx: Eurofins Electric & Electronic Product Testing AG, Luppmenstrasse 3, CH-8320 Fehraltorf, CE 1258

ATEX certification of quality management system, type production of Ex devices, in accordance to the directive 2014/34/EU:

Certification No.: SEV 21 ATEX 4580, QAR No.: CH/SEV/QAR21.0009/01, CB: Eurofins Electric & Electronic Product Testing AG, Luppmenstrasse 3, CH-8320 Fehraltorf CE 1258.

Pablo Ledergerber, Matrix Elektronik AG, is authorized to generation of documentation.

The conformity of the devices with all used standards and directives and the EC-type examination certificate and the observation of the Quality Management System ISO 9001:2015, declares:

Ehrendingen, 6.5.2024

Pablo Ledergerber, Matrix Elektronik AG

LTG-AAC-1AA-TF_e2/2024-05-06/MP

Tippkemper-Matrix GmbH
Meegerer Str. 43, D-51491 Overath
Tel.: +49 2206 9566-0, Fax -19
info@tippkemper-matrix.de

Matrix Elektronik AG (Manufacturer)
Kirchweg 24, CH-5420 Ehrendingen
Tel.: +41 56 20400-20, Fax -29
info@matrix-elektronik.com